



Without buttons



With buttons



CURTIS INSTRUMENTS, INC. 200 Kisco Avenue, Mt. Kisco, NY 10549 • Tel. (914) 666-2971 • www.curtisinst.com

1.0 Technical Specifications

1.1 Electrical

Operating Voltage Range +/- 25% of nominal voltage

Operating Current Range - Values below reflect keyswitch in "on" position.

Gauge	Operating Voltage (VDC)	Nominal (mA)	Max (mA)*
12VDC	12	19	155
	12	14	140
12 - 48VDC	24	16	140
	36	16	140
	48	17	140

* Maximum current draw listed based upon all icons illuminated. Each icon draws 15mA.

1.2 Mechanical

Display: LCD with 10-segment bar and 5 digit numeric (5mm high)

Hour Meter Range & Resolution: 9,999.9 Maintenance Hours
99,999 Total Hours

Panel Cutout: 45 x 92 mm rectangular

1.3 Environmental

Shock SAE J 1378 Amplitude
44-55 g, half sine, 9-13 ms duration

Vibration SAE J 1378 Double amplitude of 1.53mm with frequency sweep
for 10-80-10 Hz (20 g max) at 1 minute intervals

Operating Temp.: -40°C to +85°C

Storage Temp.: -50°C to +90°C

Humidity: 95% RH (non-condensing)

IP Rating: 65 Front & Rear with AMP connector installed
65 Front, 40 Rear with Molex connector installed

2.0 Installation



AMP Connector	AMP Pin #	Description	Molex Pin #	Molex Connector
J1	1	LED 7 Warning Icon	5	J1
J1	2	LED 8 Warning Icon	6	J1
J1	3	LED 6 Warning Icon	7	J1
J1	4	Input 1-A Input for voltage based sender OR auto-ranging: pin in BDI applications. See schematic diagrams for AMP and Molex Connections.	8	J1
J1	5	V(-) Supply Voltage Negative Terminal	1	J1
J1	6	FET Out MOSFET (0.5A) open drain type internally tied to V(-)	2	J1
J1	7	V(+) Supply Voltage Positive Terminal	3	J1
J1	8	Input 1-B Input for resistance based senders.	4	J1
J2	1	Input 2-A Input for voltage based sender.	6	J2
J2	2	Keyswitch Activates gauge display. For BDI applications, monitoring continues when display is off.	7	J2
J2	3	Digital Input A No Connection	8	J2
J2	4	Digital Input B No Connection	9	J2
J2	5	LED 5 Warning Icon	10	J2
J2	6	No Connection – Do Not Use	1	J2
J2	7	No Connection – Do Not Use	2	J2
J2	8	Setup Enable Bringing power to this pin allows the gauge to be programmed via the front panel buttons if so equipped.	3	J2
J2	9	Hour Meter Enable Bringing power to this pin allows accumulation of time with keyswitch closed.	4	J2
J2	10	Input 2-B Input for resistance based senders.	5	J2

2.1 Terminal Assignments

See wiring schematic drawings on last page.

2.2 Typical Wiring Diagrams

See wiring schematic drawings on last page.

2.3 Mounting

Curtis enGage™ III is mounted in a 45X92 mm rectangular cutout. In addition to the snap-fit case design, an optional mounting bracket is available.

2.4 Interconnect

Curtis enGage™ III is available with AMP (8 pin & 10 pin) or Molex (8 pin & 10 pin) connectors. See complete drawing with notes on page 4 for specific part numbers.

2.5 Product Identification

2.5.1 Programmable vs. Factory Set Instruments

Curtis enGage™ III is available with or without front panel buttons. Gauges without buttons are factory set and cannot be adjusted. Gauges with buttons have field adjustable parameters and can be programmed per section 2.6.

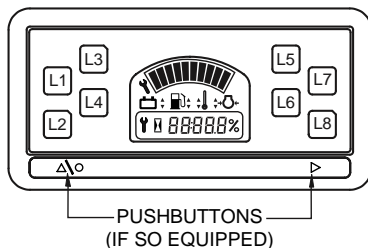

2.5.2 Curtis enGage™ III & Multifunction Design

Curtis enGage™ III products can be configured in a variety of ways to maximize customer value and efficiency. The instruction manual covers a broad spectrum of products. Please note that some sections of the instructions may refer to functions not included in your instrument.

2.6 Configuring Your Gauge

Access to these operations is sequential in this order. Adjustments of the following functions can be performed in the Configuration Mode:

1. Time-of-Day Clock
2. Battery Discharge Indicator (BDI) profiles
3. Maintenance interval
4. Settable hour meter

During configuration, the right button ► is used to increment. The left button ▲/● is used to: 1. enter a selection; 2. advance to the next configurable item. If no change is desired to a specific gauge function, continue to press the left button ▲/● until the next desired function is reached.

The time-of-day clock is entered by setting the hours digits between 01 and 12, then "minutes" digits between "00" and "59".

The profile of the BDI is settable with the front panel buttons. The Discharge Full profile (when the gauge will begin calculating 'discharge') is adjustable from 1.80 through 2.30 volts per cell (VPC) in 0.01 VPC increments. The Discharge Empty profile (when the gauge will indicate 'empty') is adjustable from 1.50 through 2.20 VPC in 0.01 VPC increments.

The maintenance interval (when the gauge signals that maintenance is due) is configurable and should be set after the initial installation. The interval can be set between 1 and 9,999 hours in 1 hour increments.

The settable hour meter can be set to any value between 0 and 99,999 hours. When the gauge is operational, the total hour meter will begin from this value.

Configuration Notes:

The gauge remains in configuration mode for 30 seconds without input from the user.

When configuring each function (time-of-day, maintenance interval, etc.), you must enter in all data for that function for it to be saved. If incomplete data is entered for a function and the programming mode is timed out (after 30 seconds of no input received by the gauge), the gauge will revert back to what was previously stored for that item.

If you interrupt the data entry process in the Configuration Mode, the gauge saves data in those sections already completed. To complete configuration, re-enter configuration mode (2.6.1) and simply toggle past the completed sections and resume where you left off.

2.6.1 Entering Configuration Mode

- a) Apply main power (9-60VDC) to V+, V-.
- b) Apply V+ (9-60 VDC) to Keyswitch Input.
- c) Apply V+ (9-60 VDC) to Set-up Enable.
- d) Press and hold the left button ▲/● on the front panel until the entire display flashes and then release.

2.6.2 Setting the Time-of-Day Clock



The display flashes the two "Hours" digits. Press the right button ► to increment by one hour, or hold the button to increment continuously. When the desired number of hours is reached, press the left button ▲/● once. The display flashes the two "Minutes" digits. Press the right button ► to increment by one minute or hold the button to increment continuously. When the desired number of minutes is reached, press the left button ▲/● once.

2.6.3 Setting the Battery Indicator Profiles



The display flashes the three digits of the discharge full profile (factory setting is 2.09 VPC). Press the right button ► to increment by 0.01 VPC or hold the button to increment continuously. When the display reaches 2.30 it will automatically restart at 1.80 VPC. When the desired reset profile setting is reached, press the left button ▲/● once.



The display flashes the three digits of the discharge empty profile (factory setting is 1.73 VPC). Press the right button ► to increment by 0.01 VPC or hold the button to increment continuously. When the display reaches full it will automatically restart at 1.50 VPC. When the desired reset profile setting is reached, press the left button ▲/● once.

2.6.4 Setting the Maintenance Interval



The display flashes the left digit (tens of thousands of hours). Press the right button ► to increment by one or hold the button to increment continuously. When the desired number is reached, press the left button ▲/● once to proceed to the next digit. Repeat this process for all 4 digits.

2.6.5 Setting the Total Hour Meter



The display flashes the left digit (tens of thousands of hours). Press the right button ► to increment by one or hold the button to increment continuously. When the desired number is reached, press the left button ▲/● once to proceed to the next digit. Repeat this process for all 5 digits.

2.6.6 Exiting Configuration Mode

The configuration mode can be exited in three ways:

- a) Press and hold the left button ▲/● for three seconds.
- b) Leave buttons untouched for 30 seconds.
- c) Press the left button ▲/● after selecting the last (right) digit of the last function available.

3.0 Operation



When the main power (9-60 VDC) is applied to V+ and V-, a power-up sequence is initiated. All display segments are illuminated for one second. The display is then turned off until the keyswitch is activated.

3.1 Button Use During Normal Operation

3.1.1 Toggling Display Functions

Should your gauge be so equipped, press the left button ▲/● to sequentially toggle between the three numeric gauge functions (time-of-day clock, maintenance hours, total hours).

The following procedures (3.1.2 and 3.1.3) can be done without V+ applied to Setup Enable pin.



Press and hold the left button ▲/● on the front panel until the entire display flashes and then release.

3.1.2 Toggling Between Bargraph (Upper) Display Functions

Should your gauge be so equipped, press the right hand button ► to toggle between the two bargraph displays.



3.1.3 Setting/Changing the Time-of-Day Clock

See Section 2.6.2.

3.1.4 Resetting the Maintenance Hour Meter

Press the left button ▲/● until the maintenance hour meter function is displayed (the wrench icon will be illuminated). Press and hold both the right button ► and the left button ▲/● until the display flashes and the maintenance hour meter is reset to zero. This can be performed at any time, independent of the actual maintenance status.

3.2 Auto-range

Curtis enGage™ III will automatically recognize one of the following 4 battery voltages: 12VDC or 36VDC - 24VDC or 48VDC based on the status of the auto-range input pin.

3.3 Output and Warning LED

3.3.1 LCD Warnings and MOSFET Activation

Curtis enGage™ III provides LCD warnings and MOSFET activation as follows

Primary Function	LCD Status	FET
BDI	Battery Symbol & LMB Flashing	LMB Flashing
Fuel	Fuel Symbol & LMB Flashing	LMB Flashing
Temp	Temp Symbol & RMB Flashing	RMB Flashing
Pressure	Pressure Symbol & LMB, RMB Flashing	LMB, RMB Flashing
Tachometer	(No LCD Symbol) RMB Flashing	RMB Flashing
Maintenance Due	Maintenance Symbol & LMB Flashing	LMB Flashing
Voltage	Battery Symbol, 2nd LMB & RMB	2nd LMB & RMB

KEY: RMB = Right Most LCD Bar / LMB = Left Most LCD Bar

3.3.2 LED Warning Icons

Curtis enGage™ III provides up to 8 LED based warning icons as shown.

Of the 8 LED icon's available, the 4 on the left side of the gauge are controlled by the microprocessor and are factory programmable. The remaining 4 icon's on the right side are activated by inputs that are switched to ground (see typical wiring diagrams sec 2.2).

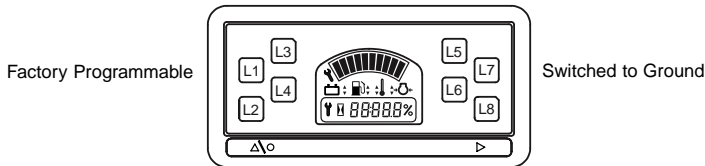

Factory Programmable

Switched to Ground

3.4 LCD Icons

Curtis enGage™ III uses a number of icons (depending on functions chosen) to assist the user:

- ⌚ a) Hourglass Icon - Turned on (not blinking) to indicate that an hour meter is displayed in the numeric display. Flashes to indicate hour meter accumulation.
- 🔧 b) Wrench Icon - Turned on (not blinking) to indicate that the maintenance hour meter is displayed in the numeric display. Flashes when the maintenance interval is reached.
- ⌚ c) Colon - Flashes to indicate that the time-of-day clock is being displayed in the numeric display and that time is counting-up.
- ⌚ d) Decimal Point - To indicate 1/10 of an hour on the maintenance hour meter
- ⛽ e) Fuel or Battery Icon - Turned on (not flashing) depending on which function the gauge is programmed to monitor. It flashes when a low condition is detected.
- % f) Percent - Indicates remaining percentage of interval or level.
- ⬆️⬆️ g) Up/Down - Indicates whether function is displayed as bargraph or numeric.
- 🌡️ h) Thermometer Icon - Flashes at high temperature condition.
- ⚡ i) Pressure Icon - Flashes at low and high condition.

3.5 Resetting BDI

OCR – Open Circuit Reset

The BDI will reset when gauge is disconnected from discharged battery and reconnected to a fully charged battery.

CTR – Charge Tracking Reset

Battery state-of-charge will be tracked by gauge during any charging period(s).

4.0 Troubleshooting

BDI Function

Problem	Possible Cause
No Display	Terminals not connected. Improper voltage.
Stays At FULL	Instrument voltage does not match battery voltage. V+ connected to wrong terminal.
Will Not Reset	Instrument voltage does not match battery voltage. Battery not fully charged. Battery may be defective.
Resets Without Charging Battery	No connected directly to battery terminals.
EMPTY Too Soon	V+ connected to wrong terminal. Instrument voltage does not match battery voltage. Terminals not directly connected to battery.
Will Not / Cannot Configure	Procedure in section 2.6.3 not being followed. No power to Setup Enable Pin.

Sender Function

Problem	Possible Cause
No Display	Terminals not connected. Improper voltage.
Stays At FULL	V+ connected to wrong terminal. Sender or sender connection problems.
EMPTY Too Soon	V+ connected to wrong terminal. Sender or sender connection problems.

Maintenance Function

Problem	Possible Cause
Will Not Reset	Section 3.1.4 procedure no being followed.

5.0 Maintenance

The enGage™III 3000 Series is not serviceable.

Safety Instructions

- This instrument was manufactured and tested according to the applicable technical standards. It complies with all the safety regulations as shipped from the factory.
- Installation and startup must be performed by skilled personnel.
- Failure to install and operate the unit in accordance with these instructions may result in damage or injury.
- If safe operation of the instrument can no longer be ensured, stop and secure it against accidental operation.
- If instrument failure or malfunction may cause personal injury or material damage, use additional safety measures such as limit switches, guards, etc.
- Read the Operating Instructions carefully before startup.
- Note the safety instructions marked with this warning symbol ⚠ in this manual.

Guarantee

Curtis Instruments' products and/or components are guaranteed against defects in workmanship and material for a period of two years, or as defined in the individual product literature, from date of shipment from our factory, when applied in a proper application within specified ratings. This guarantee is limited to repair or replacement F.O.B. our factory. There is no further warranty or implied representation, guarantee, promise or agreement as to any Curtis Instruments product and/or component. Curtis Instruments, Inc., cannot assume responsibility or accept invoices for unauthorized repairs to its products and/or components, even though defective. In no case will Curtis Instruments' responsibility extend to products, components or equipment not of its manufacture. Under no circumstances shall Curtis Instruments, Inc., be liable for any special or consequential damages or loss of profits or other damages. Returned goods will not be accepted unless identified by a Curtis Return Material Authorization (RMA).

All specifications are subject to change without notice.

2.3 Mounting/Dimension Drawing

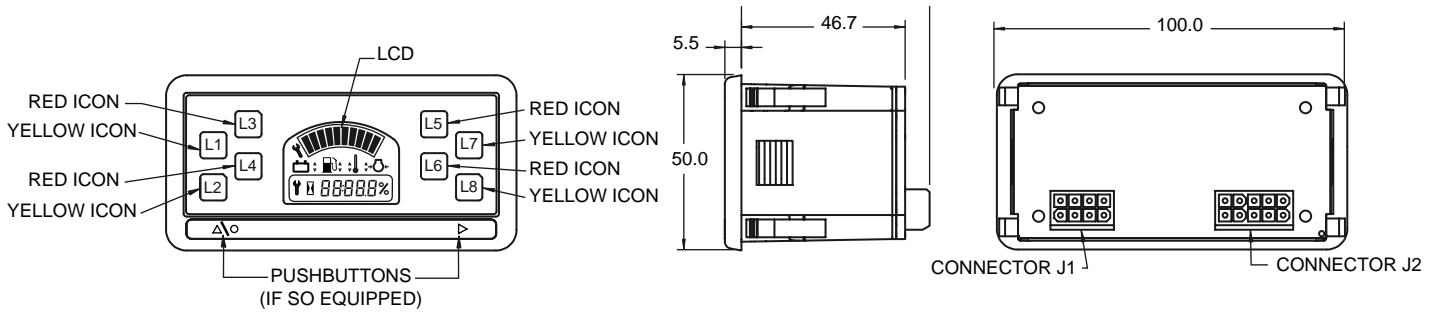

	MOLEX MATING CONNECTORS		AMP MATING CONNECTORS	
	J1	J2	J1	J2
CONNECTOR	MOLEX #39-01-2105	MOLEX #39-01-2085	AMP #794821-1	AMP #794781-1
PIN	MOLEX #39-00-0039		AMP #770904-1	
GASKET			AMP #784772-8	AMP #1-794772-0
WIRE SEAL			AMP #794758-1	

- NOTES:
 1) CASE MATERIAL: ABS/PC BLEND, BLACK
 2) LENS MATERIAL: POLYCARBONATE
 3) PANEL CUTOUT SIZE: 45 +.6/-0 X 92 +.8/-0
 4) ALL SENDER CHARACTERISTICS TO BE DETERMINED

2.2 Typical Wiring Diagrams

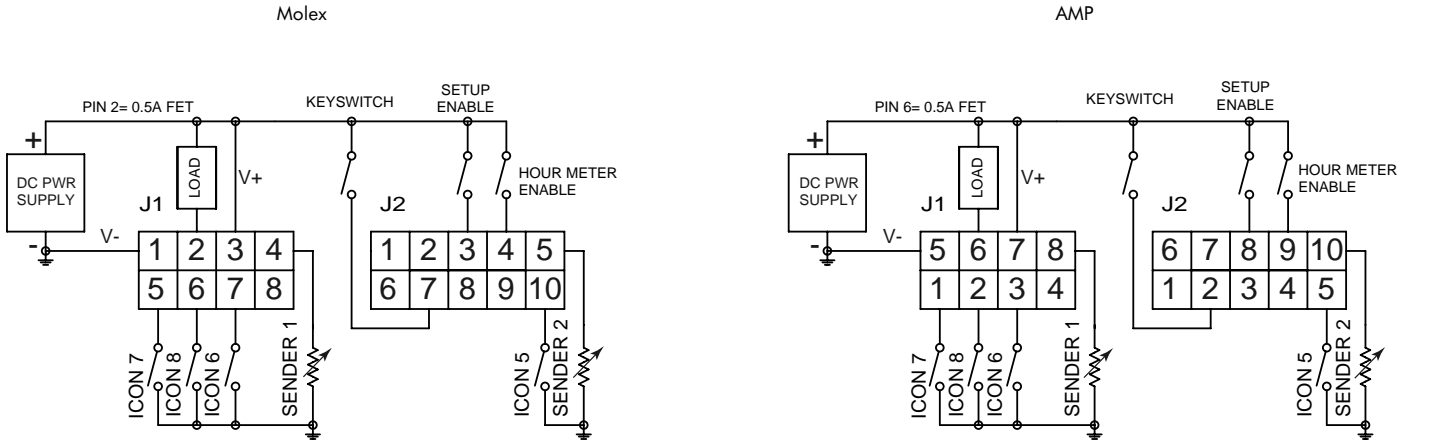

Resistive based sender input (i.e. temp, fuel and pressure).

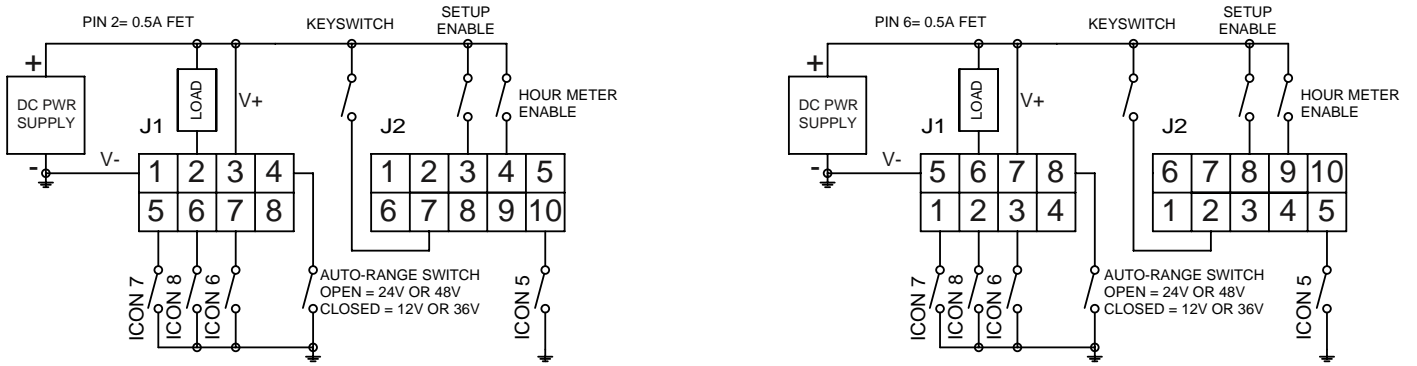

BDI (with auto-range switch)

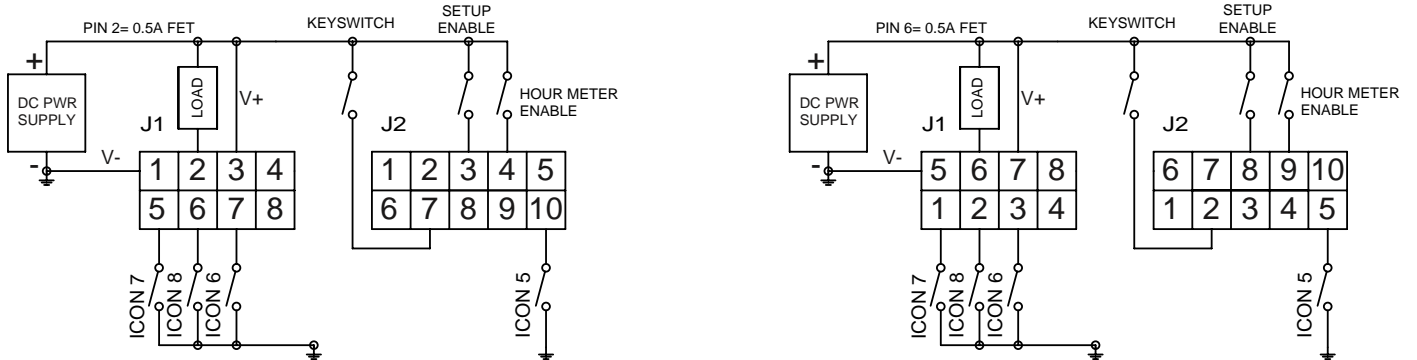

Voltmeter